



MT166DP

Ageing Wine Cellar
Prestige
Built-in



GENERAL INFORMATION

Number of bottles : 172
Number of zones : 2
Adjustable temperature range : 5-20°C
Noise level : 39dB
Energy class : F
Climate class : SN/ST (10-38)
Vinotag compatible : Yes

Product description

BUILT-IN & FREE-STANDING

The MT166DP has the particularity of being able to be installed free-standing or built-in. Its multi-choice installation allows it to integrate easily into your interior, whether in your living rooms or in your kitchen.

LOW-E GLASS

The cellar door ensures optimal security, the 2 locks protect the wine in your absence wild the glazing door with low-E glass filter protects the bottles from UV and reduces the exchange of cold and heat between the interior of the cabinet and its external environment to achieve real energy savings.

ACCOMPANY YOUR WINES AT THEIR PEAK DATE

Thanks to its 2 zones, with independent door and settings, age and bring to tasting temperature several types of wine in the same cellar. Aging cellar commitments, age your wines in complete safety. The MT166DP aging cellar concentrates essential characteristics to reproduce the storage conditions of a natural cellar: constant temperature, controlled humidity, anti-vibration technology (SilentBlock), air renewal system (active carbon filter) and protection against the light.

OPTIMIZED STORAGE



DUAL TEMPERATURE ZONE

Store and refresh all your wines at the correct temperature in the same cellar



SIDE LED LIGHT

Improves visibility of your wine selection with interior side LED lighting (top to bottom of the cellar)



LOCK

Secure your wine collection in all time



INSTALLATION

Both free standing and built-in you can install your cellar at the location of your choice

MT166DP

EAN-13 - 3541362209030

Capacity and Temperature

- **Number of bottles: 172**
 - Upper zone : 67
 - Lower zone : 105
- **Adjustable temperature: 5-20°C**
 - Upper zone : 5-20°C
 - Lower zone : 5-20°C

Door

Door color : Stainless steel
Door glass color : Grey
Number of glass layers : 2
Anti-UV : Yes
Low-e glass : Yes
Tempered glass : Yes
Lock : Yes
Reversible door : No
Handle type : Pulling bar

Security

Alarm : Temperature, Door
Winter system : No
Child lock : Yes
Temperature memory : Yes

Logistic

Net dimensions (WxDxH): 59.8 x 68.5 x 192.5
Gross dimensions (WxDxH): 65.5 x 77.0 x 196.0
Net weight (kg) : 87.0
Gross weight (kg) : 95.0

Technical Data

Energy class : F
Annual energy (KWh/a) : 140
Climate class : SN/ST (10-38)
Noise level : 39dB / C
Energy Efficiency Index : 122.9 %
Power input : 160.00 W
Voltage : 220-240 V
Length of power cable : 250 cm
Plug Type : E type
Type of gas : R600a
Gas charge : 60 g
Type of compressor : Standard
Main cooling system : Air moving system
Charcoal filter : 1
Anti-vibration system : Yes
Adjustable feet : 4 / 1 cm

Light

Light source : LED
Light color(s) : Cold White
Dimmable light : no
Light switch : yes

Qty per 20' : 24
Qty per 40' : 54
Qty per 40 HC : 54
Customs code : 8418501990

MT166DP

EAN-13 - 3541362209030

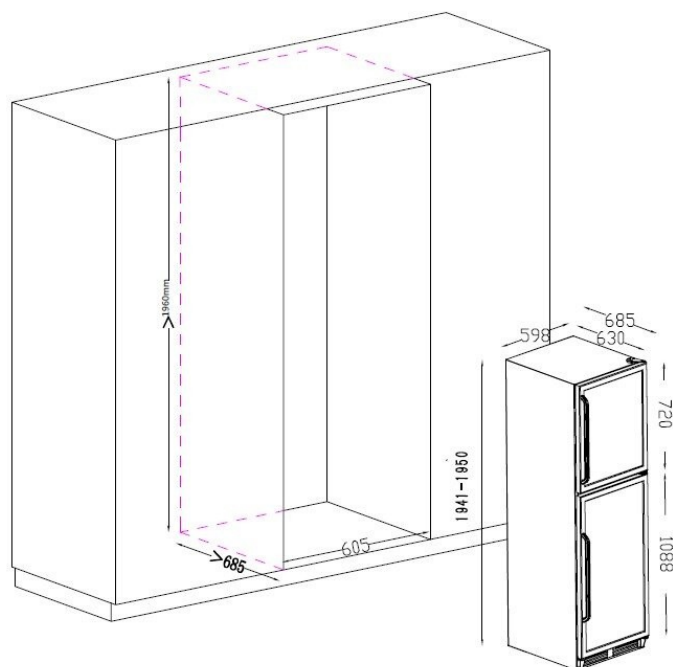

Accessories

- 1 charcoal filter, (FILTRE4)
- 8 shelves, wooden with stainless steel front, sliding, rails

Compatible accessories references : PIERREDELAVE, BOITEPOURPIERRES, FILTRE4

Built-in information

Built-in dimensions (WxDxH) : 60.50 x 68.50 x 196.00

Installation warning : This product is equipped with a front ventilation system. Follow the installation instructions to ensure proper operation of the unit.