



CBU20S2B

Wine Cellar service

Built-under counter



GENERAL INFORMATION

Number of bottles : 20

Number of zones : 1

Adjustable temperature range : 5-20°C

Noise level : 38dB

Energy class : F

Climate class : N/ST (16-38)

Vinotag compatible : Yes

Product description

The Wine Cellar That Elevates Your Tastings

At just **30 cm wide**, this built-in under-counter wine cellar is the perfect ally for wine enthusiasts seeking elegance and practicality in a compact design. Its temperature zone brings your bottles to the ideal serving temperature, unlocking the full depth of their aromas.

Equipped with a **removable ventilation grille**, it ensures discreet and optimal installation, blending seamlessly into your space. Its **reversible door** adds extra flexibility to adapt perfectly to your setup, while its compatibility with the Vinotag app lets you manage your wine collection like a professional. A true combination of technology and sophistication for your finest vintages.



ENERGETIC PERFORMANCE

Reduce your energy consumption by choosing a device with optimal energy performance

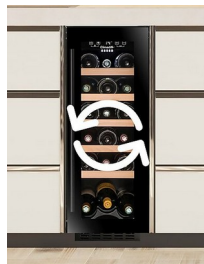

REVERSIBLE DOOR

Adapt the direction of opening of the door to easily install the cellar in the location of your choice



REMOVABLE PLINTH

The plinths are removable and replaceable by any common perforated plinth

VINOTAG COMPATIBLE

Free wine cellar management application. Access a virtual representation of your cellar and a detailed inventory

CBU20S2B

EAN-13 - 3595320107517

Capacity and Temperature

- **Number of bottles: 20**
- **Adjustable temperature: 5-20°C**

Door

Door color : black windows effect
Door glass color : Grey
Number of glass layers : 3
Anti-UV : Yes
Low-e glass : Yes
Tempered glass : Yes
Lock : No
Reversible door : Yes
Handle type : Pulling bar

Security

Child lock : Yes
Temperature memory : Yes

Logistic

Net dimensions (WxDxH): 29.5 x 57.0 x 82.0
Gross dimensions (WxDxH): 33.0 x 63.5 x 85.5
Net weight (kg) : 29.0
Gross weight (kg) : 31.0

Technical Data

Energy class : F
Annual energy (KWh/a) : 82
Climate class : N/ST (16-38)
Noise level : 38dB / C
Energy Efficiency Index : 103.7 %
Power input : 58.00 W
Voltage : 220-240 V
Length of power cable : 150 cm
Plug Type : E type
Type of gas : R600a
Gas charge : 19 g
Mainly recyclable product : Yes
Type of compressor : Standard
Main cooling system : Air moving system
Charcoal filter : 1
Anti-vibration system : Yes
Adjustable feet : 4 / 6 cm

Light

Light source : LED
Light color(s) : White
Dimmable light : no
Light switch : yes

Qty per 20' : 148
Qty per 40' : 303
Qty per 40 HC : 387
Customs code: 84185090

CBU20S2B

EAN-13 - 3595320107517

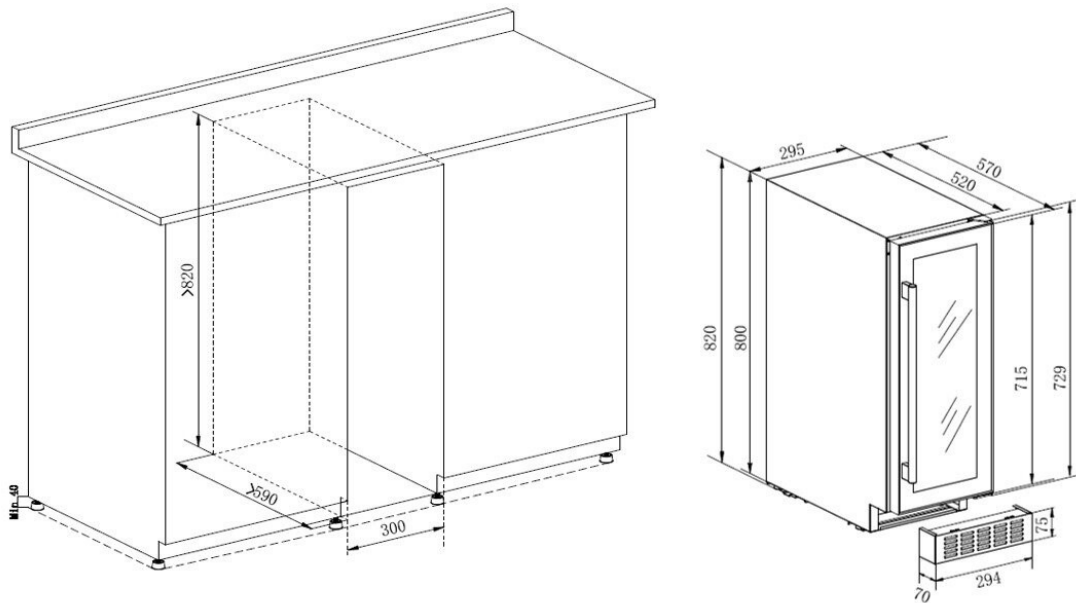

Accessories

- 5 shelves, wooden, sliding

Compatible accessories references : FILTRE7

Built-in information

Built-in dimensions (WxDxH) : 30.00 x 57.50 x 81.50

Plumbing passage : No

Plinth height : 7.50

Removable plinth : Yes / 7.00

Installation warning : This product is equipped with a front ventilation system. Follow the installation instructions to ensure proper operation of the unit.